

A New Imaging X-Ray Crystal Spectrometer Advances State-of-the-Art for Measurements of Ion Temperature and Plasma Rotation Velocity Profiles in Tokamaks

A PPPL/MIT collaboration on Alcator C-Mod has resulted in the demonstration of a greatly improved x-ray crystal spectrometer for measurement of radial profiles of the ion temperature and rotational velocity of high temperature plasmas in ITER and fusion reactors without the need for diagnostic beams.

The Problem: X-ray crystal spectrometers measure the x-ray line spectra emitted by intrinsic or injected heavy impurity ions in tokamak plasmas. These spectra provide information on the ion and electron temperatures and plasma rotation velocities. However, due to the lack of mirrors, lenses, and fiber bundles — which are available for optical spectroscopy but not for x-ray spectroscopy — it is more difficult to obtain spatially resolved x-ray spectra and thus radial profiles of the above mentioned plasma parameters.

Due to the large size of crystal spectrometers and the precious real estate around major tokamaks, typically only one or, at most a few, such instruments were installed on a tokamak to obtain data from a few points on the radial profile. The information obtained, however, was inadequate for detailed comparisons with theoretical predictions of plasma transport from modern computer codes.

The Solution: The x-ray imaging crystal spectrometer, which has now been installed on Alcator C-Mod tokamak at the MIT Plasma Science and Fusion Center, is based on a new concept that eliminates the longstanding limitations on x-ray measurements. The new device uses a spherically-bent quartz crystal as the x-ray diffracting and imaging element, and a two-dimensional position-sensitive detector. The imaging properties of the spherically-bent crystal permit physicists to observe simultaneously x-ray spectra from multiple sightlines through the plasma and to obtain radial profiles of the ion temperature and plasma rotation velocity. Although the validity of the new spectrometer concept had been demonstrated in 2003 [Bitter *et al.*, Rev. Sci. Instrum. **75**, 3660(2004)], the use of the instrument as a routine diagnostic was only recently facilitated by the advent of novel, pixellated, semi-conductor (PILATUS II; <http://pilatus.web.psi.ch>) detector modules, which have individual counting electronics for each pixel, and a count-rate capability of 1 MHz per pixel.

Experimental Results: The new spectrometer can view the entire 72-cm height of the plasma with up to 150 sightlines. The system consists of two spherically-bent crystals and four PILATUS II detector modules – see Fig. 1, which record spectra of helium-like and hydrogen-like argon ions; it is a prototype for the ITER crystal spectrometers, since the dimensions and layout on ITER will be similar. Examples of spatially resolved helium-like argon spectra and the derived ion temperature and rotation velocity profiles are shown in Fig. 2.

Ideal for ITER: The new x-ray crystal spectrometer is ideally suited for larger, more advanced systems, and may offer a more viable alternative to the difficult and limited beam-based Charge-Exchange Recombination Spectroscopy, CHERS, measurement technique, which has been considered so far, since a CHERS-based diagnostic for future devices will require 1000-keV beams to allow adequate penetration into the core of their larger plasmas.

The development team included M. Bitter, K. W. Hill, and S. Scott of the Princeton Plasma Physics Laboratory, Princeton, NJ; J. Rice, A. Ince-Cushman, and M. Reinke of the Plasma Science and Fusion Center, MIT, Cambridge, MA; S. G. Lee of the NFRC, Korea Basic Science Institute, Taejeon, Korea; and C. Broennimann and E. F. Eikenberry of SLS, the Paul Scherrer Institute, Villigen, Switzerland. – This work was supported by the U.S. Department of Energy (DOE) contracts DE-AC02-76-CH03073, DE-FC02-99ER54572, and the DOE Diagnostic Development Initiative, Contract – 1083.

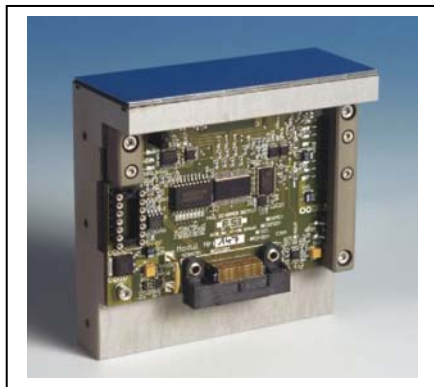
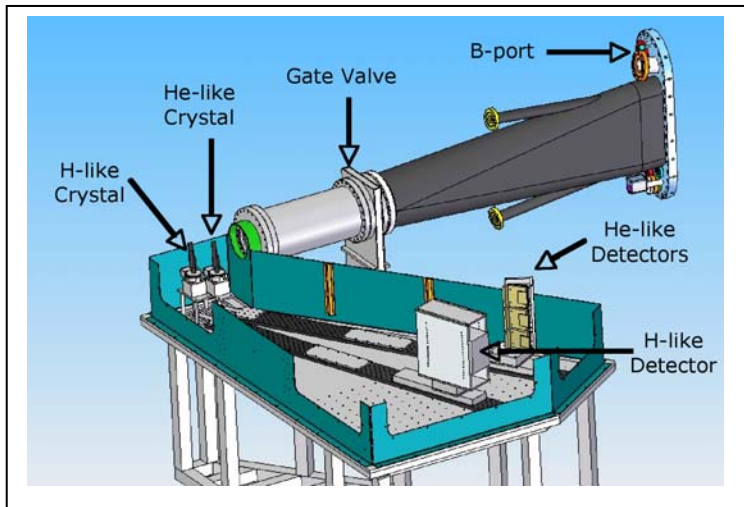

Fig. 1: (top) Imaging x-ray crystal spectrometer layout; (bottom) Pilatus II detector module.

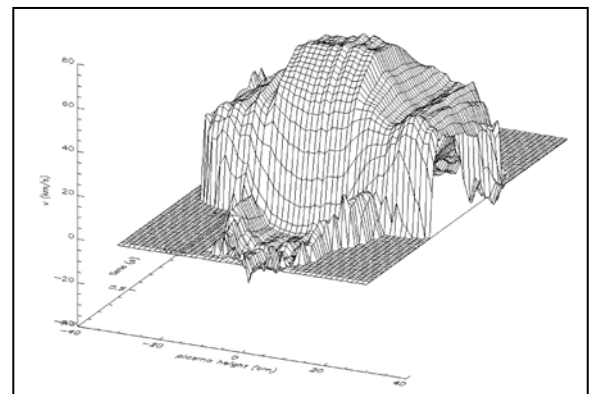
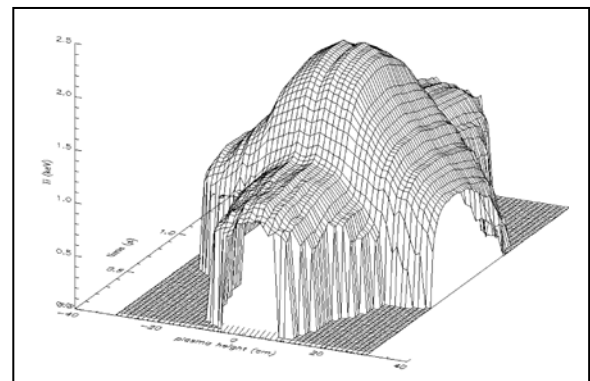
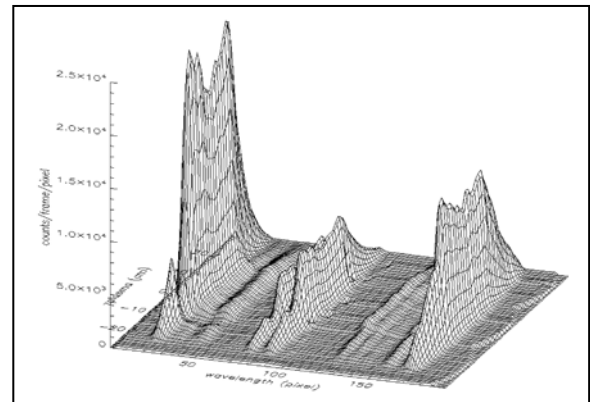

Fig. 2: (a) Spatially resolved spectra of He-like Ar; time history of (b) ion-temperature and (c) toroidal-velocity profiles.