

# FORUM ON EDUCATION

*of The American Physical Society*  
*Fall 1998*

## Message from the Forum Chair

*Paul Zitzewitz, Chair, Forum on Education*

Should the academic physics community change its system of rewards and recognitions? A report to the APS Committee on Education (COE) written by a task force recommends that, just as physics departments are now called on to be engaged in a wider range of activities, so should the faculty reward system be reformed to value those activities. The report also describes the emergence of physics education research as an important subfield and suggests ways faculty involved in this field of research can be evaluated and rewarded.

The task force report, "Faculty Rewards and Recognition in Physics" notes that the existing reward system has helped produce "an environment unsurpassed in the world for the quality of its research." The results of physics research have helped drive the U.S. economy to high levels of prosperity. The excellence of research done at our leading universities has attracted students from all over the world to our campuses. Faculty whose research efforts help produce these levels of excellence are recognized with continued grant support, tenure, merit salary increases, lower teaching loads, and access to departmental resources.

Among PhD-granting institutions, the criteria used to measure research accomplishments include quantity and quality of publications, grant support, number of Ph.D. students, invitations to speak at meetings and other institutions, evaluation letters from external reviewers, etc. At comprehensive universities and liberal arts colleges, where teaching and related activities and outreach are more highly valued, research

is still often expected. At many of these institutions a suitable sub-set of the criteria listed above are used to judge faculty research activities.

At most colleges and universities, research, teaching, and service are cited in promotion and tenure documents, with a weighting that depends on the mission of the institution. Teaching usually means performance in the classroom. Over the past few years, at many institutions both internal and external forces have resulted in increased attention to excellence in teaching. As a result, many universities have increased the weight given to the teaching leg of the triad and have developed procedures for assessing teaching success. New faculty members who have attended AAPT New Faculty Workshops report that their teaching activities are among the most exciting aspects of their jobs, but wish that their chairs would allow more time for, and place greater value on these activities.

Meanwhile, society is placing new demands on higher education. As the student body becomes more diverse and as the role of technology increases, many faculty have become involved in research in student learning, in developing new teaching methods and uses of new technologies, and in working on new curricula and outreach programs. How can the work of these faculty members be evaluated, recognized, and rewarded?

The task force report suggests that the first step is for the institution and physics program to create a clear statement of its mission. The mission will most likely include traditional

*Cont'd on pg. 2*

## Viewing Teaching as a Physicist

*Kenneth Heller*

As members of the Forum, we are concerned about science education and committed to its improvement. We know that to survive, a modern democratic country must have a population which understands and appreciates not only the fruits of science but also supports the process of science. The key to this understanding is not new technology or better curriculum, as useful as they may be. The key is effective teaching in universities and colleges, in K-12 schools, in museums and nature centers, on TV and radio, and in personal contact as parents or colleagues.

The first step toward a culture that promotes and supports effective teaching is the recognition, by both teachers and their critics, that teaching is neither easy nor natural. As in other complex human endeavors, effectiveness requires using techniques and ideas that may be counter intuitive. This is as true for teaching as it is for physics. Recognizing that teaching is a complex set of skills and not a personal

*Cont'd on pg. 3*

## IN THIS ISSUE

Message from the Forum Chair .....	1
Viewing Teaching as a Physicist .....	1
Letters to the Editor .....	2
Workshops for New Faculty .....	4
Ehlers Committee Report .....	5
Why do Faculty Value Random Comments .....	6
Improving Science Ed: Role of Scientists .....	6
NSTA Position Statements .....	8
Browsing Through the Journals .....	9
Bringing Contemporary Physics into the High School .....	11
The Vernier Software Story .....	14
Revitalization of an Undergraduate Physics Program .....	14

## Letters to the Editor

### Introductory Physical Science (IPS)

To the Editor:

On reading Rodger W. Bybee's contribution to the Spring 1998 issue of Forum on Education, I found the following statement:

"Fifth, restricting initiatives to curriculum for specific groups of students, i.e., science and mathematically prone and college-bound students, resulted in criticism of Sputnik-era reforms as inappropriate for other students such as the average and the disadvantaged."

I was astonished to find no references to Introductory Physical Science (IPS). Work on this course was begun in the summer of 1963, taught in pilot projects for three years and appeared in commercial editions in 1967. The course, now in its Sixth Edition, is widely used. The general approach to this course has been modified and expanded somewhat, but the general nature of the course is essentially unchanged.

I was a pilot teacher for three years. I had realized that the practice of testing a course with a small number of top students was worthless, that to have any real effect in the education science one needs to do pilot teaching with a teacher carrying a normal teaching load and students from a cross section of the student body. During the pilot I requested and was given a wide range of student abilities. In my third year I had three pilot classes of 30 students, in addition to my other duties that included advanced placement physics.

I made every effort to teach the complete course during the school year. I began to realize that the logical sequence of this course resulted in a significantly unified body of material with the end of each additional chapter. Hence, one could teach a good course to students of ordinary or less

than ordinary ability by teaching fewer chapters, but which will would represent a significant advance in their education. Consequently, the course is adapted to all levels of ability. The course was not and is not directed to the benefit of specific groups of students.

*John H. Dodge*  
10100 Hillview Road, Apt. 8-C  
Pensacola, FL 32514-5451

### A sophisticated toy

To the Editor:

This note is prompted by a remark in your contribution on p.2 of Forum on Education, Fall 1997: "At a high school, doing physics might mean figuring out how a sophisticated toy or a familiar appliance operates in order to explain its physical principles to students." It has been my experience that sophisticated toys usually require expertise rarely possessed by high school teachers, unless that is what a large number of PhDs will be doing in the near future, courtesy of the present job market. Henry Lenstein (Syracuse University), while running a semiconductor lab used to spend a considerable amount of time figuring out the workings of many electronic toys, and eventually put together a lecture on the subject which he delivered nationally. A notorious example of a tough toy is the LEVITRON, which was explained by M. V. Berry (of "Berry phase") in Proc. Roy. Soc. London A252, 1207 (1996). This toy certainly caused considerable controversy at Syracuse University before Berry's article clarified the situation.

*Harvey Kaplan*  
325 West 86th St., Apt. 8a  
New York, NY 10024

### *Zitzewitz, cont'd from pg. 1*

activities such as performing research and offering courses for physics majors (and, as appropriate, graduate students), courses for students in the sciences and engineering, and those in the general education program. It may also include the preparation of K-12 teachers, the recruitment of students from under-represented groups, the retention of all students, and outreach programs to disseminate knowledge to diverse audiences, on- and off-campus. The report notes that the selection of activities should be consistent with the descriptions of faculty positions and that all faculty members should have opportunities for scholarly pursuits that are personally rewarding and that advance the profession.

The challenge, the task force report notes, is to create measures to assess the effectiveness of these pursuits. The measures can answer the same questions asked about traditional research. Is it innovative? Does it have a measurable impact? Has it been disseminated? Can it be replicated? Has it been evaluated by recognized experts? Is it consistent with current research in the appropriate community? Evaluating these education-related and outreach pursuits is not evaluating teaching itself, but assessing the broader impact they have on the quality of education itself. The report suggests assessment measures that can answer these questions.

The report to the COE points out that physics education research (PER) is a specialty that belongs within the physics department rather than a school of education. It is being performed at several leading institutions, is attracting grant support, and has publication and dissemination mechanisms, including Ph.D. students establishing new programs. In order for the results of this research to improve teaching, teachers who are doing traditional research must be in close contact with physics education researchers. PER is an appropriate activity for inclusion in the mission of a institution and department and it can be assessed using measures used for more traditional research.

The report concludes by stating that the physics community has recognized the need for education reform and the need to communicate our field to diverse audiences. We have not been as ready to recognize faculty who perform these activities as physicists and as scholars. It urges physics departments and societies to broaden their reward and recognition systems to include the individuals who perform these activities whose need they acknowledge.

*Paul Zitzewitz, a member of the faculty at the University of Michigan-Dearborn, chairs the Forum on Education.*

*Heller, cont'd from pg. 1*

attribute would move us beyond recrimination by critics and defensiveness by teachers. We need to expunge the notion of a "good" or a "bad" teacher and replace it with the notion of using more or less effective techniques of teaching. Changing one's tools does not require a gut wrenching *mia culpa* that past teaching was "bad" but simply the recognition that more effective techniques are now available.

As physicists, we can view teaching dispassionately as the operation which transforms a people from their initial state to a desired final state,  $\langle f/T/I \rangle$ . Effective teaching is then the operation that maximizes the fraction of students making the transition. To find this operation, it is clear that someone must first carefully characterize the desired final state and also determine the ensemble of initial states that we are given.

When the final state involves physics, science in general, or even mathematics, we physicists should have a great deal of input. Indeed, this process has begun with the work of the American Association for the Advancement of Science in formulating "Project 2061: Science for All Americans" and the publication of the "National Science Education Standards" by the National Academy of Sciences. Of course, it is perfectly reasonable that different final states are desirable for different populations. The knowledge and skills needed by those intending careers in political science or English are probably quite different than those needed in mechanical engineering or biochemistry. Some final states might appear desirable but are "forbidden" by either the constraints or the fundamental laws governing learning. We all know that even the smartest, most skilled, and dedicated inventor cannot build a machine which violates conservation of energy.

Characterizing the initial state of students is the province of education, cognitive psychology, and the emerging fields of specific subject-matter education, including physics education. If every learner were in a completely unique state, it might be impossible to implement a finite number of operations to substantially populate any desired final state. Luckily, broad categories have been found which characterize the initial state of a large fraction of people. There do appear to be transitions that are forbidden based on the age of the learner and others which are highly suppressed in certain common learning environments. The characterization of the initial state of the learner has improved dramatically over the past twenty years and a more precise categorization will come with the increase of research support and the development of new diagnostic tools.

Based on this fairly detailed but incomplete knowledge of desired final states and initial states of the learner, a teacher must choose which transitions are desirable and possible. Then begins the construction of the relevant operator, the teaching. As in physics, random guessing is not an efficient technique although it sometimes works. Theory is needed as a guide. Such theories are provided by the fields of education and cognitive psychology. As we in physics know well, the theory does not have to be correct to be useful. After all, caloric theory was useful in guiding the early and very fruitful development of thermodynamics and Newtonian theory is still useful in many venues. A useful theory can encompass basic principles or be purely phenomenological. If the

theory does not allow detailed predictions, it should at least provide some symmetry principles. Even without strong predictive power, a theory helps organize thinking about observations.

Learning theories do exist and are useful tools in designing instruction. A phenomenological theory which has proved useful and seems to appeal to physics faculty, probably because it is reminiscent of graduate school, is called cognitive apprenticeship. This learning theory begins with the observation that apprenticeship has been an effective approach to teaching complex skills in a small group setting. It then extends that approach into the realm of more abstract learning for large numbers of people. To the extent that effective teaching is based on cognitive apprenticeship, it must incorporate elements of modeling (showing exactly how to do the desired skill), coaching (correcting individual work in real time), and fading (independent work). This theory then gives guidance for the framework necessary to teach a course. The framework, in turn, provides a structure to help teachers incorporate other empirical observations. Three of the most useful of these observations are: people have different but classifiable styles of efficiently learning; people come to any subject, that is about the real world, with a firmly established and interconnected mental structure of its concepts some of which are incorrect; and the rate of learning of related material is approximately exponential.

Determining whether or not a technique will lead to more effective teaching is difficult because learning is a complex process. It is probably non-linear. This may account for the observations that simple "controlled experiments" varying a single quantity typically show very small learning changes. When large learning changes are reported they are usually difficult to reproduce unless all parts of the learning environment are reproduced. It may be that human learning, which depends on many parameters, has resonances. Although changing each parameter in turn gives a very small effect, the parameters can be tuned to give a large effect.

As physicists we can apply the same standards to teaching as to our field. Our research is based on theory and past measurements. We don't often repeat work without good reason. When a new technique arises that enables us to attack problems more efficiently, we embrace it. Changing method, technology, or analysis technique does not cast doubt on personal worth. We do not dwell in the past nor do we demand that every new theory or experiment be a breakthrough. We take pride in our past accomplishments and marvel at all we accomplished using the tools at hand. We look forward, with some trepidation, to using the latest techniques and probing the latest theories. Powered by this attitude, the technology and techniques used in physics continuously improve. Can the same be said for teaching? Do we see the incorporation of improved teaching techniques or do we hear about the need for identifying the good and bad teachers?

*Kenneth Heller is Morse-Alumni Distinguished Teaching Professor in the School of Physics and Astronomy of the University of Minnesota. He is a Fellow of APS, a member of AAPT, and is Vice-President of the Forum on Education. His current research interest in experimental particle physics is using neutrinos to probe the standard model.*

## Workshop for New Physics Faculty — An Update

*Kenneth S. Krane*

The third annual Workshop for New Physics Faculty will be held November 12-15, 1998 at the American Center for Physics and the University of Maryland at College Park. More than 50 faculty members, generally in the first two or three years of their initial tenure-track appointment, are expected to attend the third Workshop. The Workshop is organized by the AAPT and is supported by a grant from the Undergraduate Faculty Enhancement Program in the Division of Undergraduate Education of the National Science Foundation. In the first three years, about 160 faculty members have attended the Workshops, and more than 80% of this group were from research universities (M.S.- and Ph.D.-granting). A previous report on the Workshop was given in the Summer 1996 FEd Newsletter. Readers interested in learning more about the program for the Workshop can consult the AAPT Web site ([www.aapt.org](http://www.aapt.org)).

The purpose of the Workshop is to promote the development of expertise in teaching, especially among newly hired faculty at the research universities. The basic premise is to expose the participants to a variety of new but tested and effective techniques in teaching that can be quickly implemented in their courses. Because these faculty will in their first few years be concentrating on research in order to gain tenure, the Workshop seeks to provide them with resources that will enable them to achieve simultaneous success in teaching. Session leaders at the Workshop this year will include Lillian McDermott, Eric Mazur, Bob Beichner, Dick Berg, Bob Hilborn, Evelyn Patterson, Jim Stith, Ken Heller, and Diandra Leslie-Pelecky. The Workshop format is highly interactive, with more time allocated for breakout and discussion than for lecture-type sessions.

Three follow-up sessions have provided opportunities for participants to report on their activities as well as for interactions with others, including senior faculty, graduate students, and junior faculty who were not able to attend the Workshop. These sessions have been held at the Summer 1997 and Summer 1998 AAPT meetings and at the Spring 1998 joint APS-AAPT meeting.

It has been interesting to read the evaluations from the participants in our first two Workshops. Most describe its impact in glowing terms, after admitting that they were skeptical and unsure about attending (and often did so only at the insistence of their department chairs). They have appreciated that the Workshop program has stressed implement-

ing proven reforms in teaching rather than encouraging the development of reforms.

These new faculty represent the future of our profession. In their evaluations of the Workshop, they report that what excites them about their new faculty status is: teaching, communicating their interest in physics, interacting with students, establishing a new research program, and achieving a measure of independence in their careers. Teaching and research were regarded as carrying equal weight among the activities that generated enthusiasm in their professional activities. However, many seemed at the same time frustrated that their institutions do not give adequate weight to teaching in the faculty reward and recognition system. They also reported frustrations and concerns over the failure of their institutions to assist them in setting priorities, to communicate clearly the expectations for research and teaching, and to provide adequate mentoring. Typical among the comments concerning their home departments were the following:

"Don't just give lip service to the idea that teaching is important. Give junior faculty substantial credit toward tenure for teaching excellence."

"They (my department) need to decide if they are serious about teaching. If they are, it must be seriously borne out. If not, they should not expect exceptional teaching."

"Give us less committee work but more responsibility to develop innovative teaching methods early in our career. Don't let us sink into doing things the same old way because we have no time. And reward us for good teaching."

"Develop an environment to better encourage (teaching) innovations by new faculty. The current tenure system stifles this somewhat by making short-term failure and non-traditional activities so potentially devastating to our career."

Current plans are to continue the national Workshop for at least one more year under the current NSF grant, and then to seek a renewal for another cycle of national programs. Once we have established a network of several hundred new faculty who have had the experience of the Workshop and who have put its lessons into practice, it will be possible to continue this training through a series of regional workshops.

*Kenneth Krane is a professor of physics at Oregon State University and a member of the Executive Committee of the Forum on Education.*

### APS Mass Media Fellowships (Summer)

In affiliation with the popular AAAS program, APS will sponsor two 10-week fellowships for physics students to work full-time over the summer as reporters, researchers, and production assistants in mass media organizations nationwide. The program is meant to improve public understanding and appreciation of science and technology and to sharpen the ability of the fellows to communicate complex technical issues to non-specialists. Following an intensive three-day orientation in early June at the AAAS in Washington, winning candidates will work full-time through mid-August. Remuneration is \$4000, plus a travel allowance of approximately \$1000.

Information and application forms are available from: [http://www.aps.org/public\\_affairs.html](http://www.aps.org/public_affairs.html). **Applications must be received by January 15, 1999.**

## Unlocking our Future: Toward a New National Science Policy (Ehlers Committee report)

Thomas D. Rossing

In February 1997, House Speaker Gingrich charged the House Committee on Science to develop a long-range science and technology policy for the Nation. This policy would replace the model developed by Vannevar Bush in his 1945 report to the President entitled *Science: The Endless Frontier*. Science Committee Chairman Sensenbrenner asked the Committee's Vice Chairman, Vernon Ehlers, who is a physicist, to lead a Committee to study the current state of the Nation's science and technology policies and to "outline a framework for an updated national science policy that can serve as a policy guide to the Committee, Congress and the Nation." The report of the Committee to Congress, released to the public on September 24 and available at [www.house.gov/science\\_policy\\_report.htm](http://www.house.gov/science_policy_report.htm), is well worth reading.

The report is organized into 5 major sections: I. Background and introduction; II. Ensuring the flow of new ideas; III. The private sector's role in the scientific enterprise; IV. Ensuring that technical decisions made by government bodies are founded in sound science; V. Sustaining the research enterprise the importance of education. Along with urging everyone to read the entire report, I will attempt to summarize section V, the one which makes several comments and recommendations pertaining to science and mathematics education.

Along with quoting Bacon (1597) "Nam et ipsa scientia potestas est," the introduction to this section reminds us that "In a technology-driven economy, jobs that require a scientific or technology background will gain increasing importance...We must ensure that we instill in younger generations the motivation and desire to obtain those jobs as well as the fundamental skills and knowledge to be able to perform them."

Addressing the lack of scientific training on the part of high school and especially middle school teachers, the report applauds States that implement credential programs on an accelerated schedule for persons with backgrounds in science, math, or engineering. The report also notes the relatively low salaries K-12 science teaching jobs offer compared to alternative opportunities. "School districts should consider merit pay or other incentives as a way to reward and retain good K-12 math and science teachers."

Noting that only 0.01% of the \$300 billion annual expenditure on education is spent for education research, even while "technology promises to revolutionize both teaching and learning," the report recommends that a greater fraction of Federal spending on education should be spent on research programs

aimed at improving curricula and increasing the effectiveness of science and math teaching.

On the college level, the report notes that undergraduate enrollments in physics are at their lowest levels since the Sputnik era, and that PhD programs must turn increasingly to foreign-born students to make up for declining enrollments. Similar patterns are seen in engineering, where the number of college freshmen declaring an engineering major declined by 19 percent between 1983 and 1996. This tepid interest comes at a time when many employers are in such stiff competition with each other for recently-minted engineers that they are offering signing bonuses and are petitioning the Congress to increase the number of visas granted to technically trained immigrants.

While noting that the American system of graduate education produces highly trained scientists and engineers of unparalleled quality, the report calls for "better preparation of students who plan to seek careers outside of academia by increasing flexibility in graduate training programs." Another recommendation is that universities be encouraged to put controls on the length of time spent in graduate school and post-doctoral study. Federal funding for post-docs should be expanded, and more university science programs should institute specially-designed Masters of Science degree programs as an option for allowing graduate study that does not entail the commitment to the PhD.

Finally, the report stresses the importance of communicating science to the public. Universities should consider offering scientists, as part of their graduate training, the opportunity to take at least one course in journalism or communication, and journalism schools should also encourage journalists to take at least one course in scientific writing, the report urges. Scientists and engineers, particularly those with an aptitude for public speaking, should be encouraged to take time away from their research to educate the public about the nature and importance of their work. "Those who do so, including tenure-track university researchers, should not be penalized by their employers or peers." ("not penalized" but not necessarily rewarded!)

Research sponsored by the Federal government should be more readily available to the general public, both to inform them and to demonstrate that they are getting value for the money the government spends on research. "Plain English summaries of research describing its results and implications should be prepared and widely distributed, including posting on the Internet."

### APS and AIP Congressional Science Fellowships

The American Physical Society and the American Institute of Physics are currently accepting applications for their 1999-2000 Congressional Science Fellowships. Fellows serve a one-year term on the staff of a senator, representative, or congressional committee, learning the legislative process while lending scientific expertise to public policy issues. Qualifications include a PhD or equivalent in physics or a closely related field as well as interest in policy and, ideally, experience in applying scientific knowledge to societal problems. Fellows are required to be U.S. citizens and, for the AIP fellowship, members of one or more of the AIP Member Societies at the time of application.

For more information, see <http://www.aip.org/pubinfo/flwshp.html> or call (301) 209-3094. **All application materials MUST be postmarked by January 15, 1999 to be considered.**

## Why Do Faculty Value Random Comments in Reponse to Physics Questions?

Gerhard Salinger

In the last issue of the Forum on Education newsletter, Sam Bowen, described the Third International Mathematics and Science Study (TIMSS) and the poor performance of US students on it. Elsewhere in the Newsletter, Rodger Bybee et al. describe some actions that can be taken by the physics research community to improve the performance of students. In this article, I would like to join these ideas by calling attention to student performance on the short response items on the TIMSS test and suggesting a change in assessment procedures in high school and college physics classes. The TIMSS physics test, taken by students in their final year of high school who had at least one year of physics instruction, consisted of both multiple choice and free response questions. US physics students respond to almost all of the questions whether or not they have any sense of the correct answer.

One part of the TIMSS Physics test, taken by all students, was entirely multiple choice. In addition, each student took one of three other tests that contained about half multiple choice and half short response items. On these three tests, there were a total of 24 short response questions that were generally graded on a three point scale: two points for the completely correct answer; one point for an answer that may have left out one small part; and no points otherwise. For a few questions there were no answers considered partially correct. In each category, there may be sub-categories of several partially correct responses or of specific reasons to give no points. One category of the latter, coded by 79, was "Other Incorrect Response" which I paraphrase as "random unfocussed scribbling" (with acknowledgment to Dilbert).

Upon review of the P-Value Almanac for Achievement Items on the Physics Test, it is clear that 79 is a very popular coded response for US students. Further analysis yields that 79 was the most popular response of US students in 13 items out of 24. In the other 11 cases, the fully or partially correct answer was more popular for 4 items, another category of zero points in 3 and "Problem Omitted"

in 4 items. For the international average of all students taking the test, including US students, 79 was the most popular answer for NO items, while "Omitted Problem" was most popular for 12 items, and "Fully Correct" for 6. In no other country was 79 the most popular coded response more than 6 times.

On all of the twenty-four questions, US students were more than twice as likely to respond with an answer coded as 79 than the international average of all students and about half as likely to omit the problem. The analysis also indicates that US students were more likely to give incorrect partial answers to the short response items but almost always respond even if they do not know the answer. The analysis also indicates that US students were more likely than those in most other countries to have completed the test.

A similar analysis was done on the P-Value Almanac for Achievement Items on the Mathematics test for students who had taken calculus. Again 79 was the most popular US coded response for nine items out of nineteen and in only two items on the international average. Apparently US students have learned to answer all questions and to write down anything that comes to mind in hopes that the teacher will give credit for some random thought. Why is this tactic encouraged in our students? Where, in the real world, is it a useful skill to be able to put down random comments? Not in business reports, not in research papers, not in legal briefs, not in medical diagnoses. Further, in test taking, writing random thoughts subtracts from the time students might think about other question. Faculty in all departments could adopt the grading algorithm of the TIMSS test and drive home the lesson that it is careful, reasoned thought that counts. US students would do better in the world of work and on international tests.

*Gerhard Salinger is a Program Officer at the National Science Foundation. The opinions, findings, conclusions and recommendations expressed in this article are his and do not necessarily reflect the views of the National Science Foundation.*

## Improving Science Education: The Role of Scientists

Rodger W. Bybee and Cherilynn A. Morrow

For many scientists, improving science education seems a large, continuous, and sometimes insurmountable task. After a major curriculum reform initiated by the launch of Sputnik in October 1957, many scientists and educators thought the task was pretty well completed. But, that was not the case.

The 1980s had over 300 reports documenting the dismal state of education, including science education. In the 1990s, results from the Third International Mathematics and Science Study (TIMSS) (Peak, 1996, 1997) provided yet another indicator of the need to improve science education. We can probably identify two reasonable conclusions from this snapshot of educational history. First, one effort of any sort will not, once and for all time, settle our educational problems. And second, any one group, scientists or educators, will not provide the entire solution. Improving science education is a continuous effort, one that has to involve scientists and educators working in a coordinated manner. The magnitude of the problem can be summarized by pointing out that there are about 44,000,000 students in grades K-12 being taught by 3,000,000 teachers in 90,000 schools in 14,500 school districts.

In this short article, we address one issue about the scientists

and educational improvement: How can scientists become involved in precollege science education so their involvement is coordinated, accommodates their interests and talents, and ultimately contributes to educational improvement?

**The National Science Education Standards**—One way we increase the coordination of efforts is by using a common document as the foundation for our work. We suggest that the National Science Education Standards (NRC, 1996) can provide that foundation. In late fall 1995, the National Research Council (NRC) released voluntary national standards for science education (NRC, 1996).

The process of developing these standards involved thousands of individuals representing various components of the science education community. Some of the best scientists and engineers from colleges, universities, business, and industry identified the fundamental concepts and abilities that all students should know and develop. Some of the best science teachers from elementary, middle, and high schools clarified the essential characteristics of effective teaching and professional development, and some of the best science educators from schools of education, state departments, and curriculum development

organizations identified standards for assessment, science programs, and the educational system.

All of us must look beyond the process of developing standards and address the next phase using the Standards to improve school science programs and classroom practices. Using the national standards assumes some understanding of their purpose and place in reform efforts.

**Understanding the Standards**—Our first recommendation is to study the Standards; read the entire document, not just the content for your discipline or sub-discipline. The Standards are intended to be a coherent set of policies that are interdependent and interrelated. National standards are voluntary policies; they are not curriculum programs, assessment exercises, or classroom activities. As policies, standards provide guidance in the development of curriculum and assessment. The Standards should inform decisions and should give direction. However, the use of standards must primarily occur in states and local school districts and ultimately in science classrooms. State educational departments, boards of education, and science teachers must decide what their students will learn and how they will learn.

National standards may be used to help make decisions about science curriculum, textbook adoption, professional development, and assessment practices. However, in all cases, local

personnel have the freedom to make the final decisions. This point is important, as it should counter the misconception that national standards are Federal mandates, which they are not. Elsewhere, one author has described the uses of standards by scientists and engineers in greater detail (Bybee, 1998).

College and university scientists should consider what the standards mean for their own teaching. Some of the content may be different, but the teaching and assessment standards increase learning by all students. In addition, some of the students in their classes may become future teachers, who need to see the teaching and assessment standards modeled in the science courses that they take.

**Roles for Scientists in Education**—We turn to another important issue: the ways scientists can be involved in K-12 education. Our position is that scientists can be involved in a variety of ways that accommodate their talents, time, and interests and in ways that are ultimately helpful to the educational system. Traditionally, many scientists have made school visits, acted as role models, and taught single lessons. Although helpful, there are much broader and deeper ways that the expertise of scientists and engineers may contribute to educational reform. At the college level, faculty should consider developing collaborations with faculty in their school of education. Developing a real understanding of the issues faced in both disciplines can

**\*Figure 1. A Sampling of Roles for Scientists in Education**

LEVEL OF INVOLVEMENT=>	ADVOCATE	RESOURCE	PARTNER
<b>K-12 STUDENTS</b>	<ul style="list-style-type: none"> <li>Participate in PTA.</li> <li>Talk to school board about importance of science education.</li> </ul>	<ul style="list-style-type: none"> <li>Judge a science fair.</li> <li>Answer student e-mail.</li> <li>Give tour of research facility.</li> </ul>	<ul style="list-style-type: none"> <li>Mentor a student in your laboratory.</li> <li>Partner with students in a research project.</li> </ul>
<b>IN-SERVICE K-12 TEACHERS</b>	<ul style="list-style-type: none"> <li>Speak out in support of appropriate professional development opportunities for teachers.</li> </ul>	<ul style="list-style-type: none"> <li>Answer teacher e-mail about science content questions.</li> <li>Present in teacher workshop or some aspect of science.</li> </ul>	<ul style="list-style-type: none"> <li>Work with a teacher to implement curriculum.</li> <li>Hire a teacher intern.</li> </ul>
<b>SCHOOLS OF EDUCATION</b> (Pre-Service Teachers, Graduate Students, Faculty Members)	<ul style="list-style-type: none"> <li>Speak out in your department or organization in favor of closer ties with Colleges of Education.</li> <li>Speak favorably of teachers and the teaching profession in your undergraduate classes.</li> </ul>	<ul style="list-style-type: none"> <li>Teach a science course or workshop segment for pre-service teachers.</li> <li>Collaborate with education faculty to improve courses on teaching science.</li> </ul>	<ul style="list-style-type: none"> <li>Hire a graduate in education to work as evaluator or co-developer of education project.</li> <li>Develop a science course or curriculum for teachers-to-be.</li> </ul>
<b>SYSTEMIC CHANGE</b> (District, State, National)	<ul style="list-style-type: none"> <li>Speak out at professional meetings about the importance and value of scientist involvement in systemic change.</li> </ul>	<ul style="list-style-type: none"> <li>Review science standards for science accuracy.</li> <li>Review the state framework for science education.</li> </ul>	<ul style="list-style-type: none"> <li>Collaborate on writing or adapting science standards.</li> <li>Participate on state boards for adoption of standards, instructional materials, or teacher certification.</li> </ul>
<b>EDUCATIONAL MATERIALS DEVELOPMENT</b> (NSRC, EDC, Lawrence Hall)	<ul style="list-style-type: none"> <li>Speak out at a school board meeting for adopting exemplary educational materials.</li> </ul>	<ul style="list-style-type: none"> <li>Agree to serve on an advisory board for a science education project.</li> <li>Review science educational materials for science accuracy.</li> </ul>	<ul style="list-style-type: none"> <li>Collaborate to create exemplary science education materials.</li> </ul>
<b>INFORMAL EDUCATION</b> (Science Centers, Scouts, Planetaria)	<ul style="list-style-type: none"> <li>Participate on the board of a science center, planetarium, environmental center, or museum.</li> </ul>	<ul style="list-style-type: none"> <li>Review science content of scripts for science exhibits, planetarium shows, or environmental programs.</li> <li>Give talk at a science center.</li> </ul>	<ul style="list-style-type: none"> <li>Collaborate in creation of a museum science exhibit or planetarium show.</li> <li>Serve as science coordinator for a scout troop.</li> </ul>

CA Morrow Space Science Institute 2/97 \*The idea for Figure 1 emerged from a 2-day meeting co-convened by Project ASTRO and Space Science Institute (SSI) in February 1997. Key scientist-educators from around the country considered what the proper content of a 1-day workshop in education for scientists should be. The group that produced the table's framework included Cherylynn Morrow (SSI), Dennis Schatz (Pacific Science Center), and Michael Bennett (Project ASTRO). After this meeting, Morrow filled in the boxes with a sampling of roles that reflect the different types and levels of involvement a scientist can have in K-12 education.

lead to better education for all students including future teachers. Further, faculty in four-year colleges and universities should develop teaching and research liaisons with faculty in near-by, two-year colleges. Two-year college faculty have found strategies to engage students having much greater diversity as measured along any dimension. Many future teachers take all of their science courses in two-year colleges before transferring to the four-year institutions.

One author (Morrow) has proposed a framework that describes the different levels of involvement in a variety of activities that contribute to improving science education. One can advocate, be a resource, or join as a partner in different components of the educational system. Advocating, for example, does not require the time and commitment as does becoming a full partner and joining in the work of teaching or developing instructional materials. Acting as a resource is a good intermediate level of involvement. Figure 1 describes a variety of options in which faculty can be involved from local efforts in one classroom, to district-wide activities, to national-level efforts. Time commitments can be fairly small or extensive. All of the components listed provide opportunities for meaningful and helpful involvement, especially if faculty will interact by learning the issues faced by the school personnel.

**Conclusion**—In this brief article, we have recommended that scientists use the National Science Education Standards

as the foundation for their involvement in K-12 education. Further, their level of involvement can include advocacy, resource, or partnership within a variety of activities in the educational system.

**References:** Bybee, R. W. (1998). Improving precollege science education—The involvement of scientists and engineers. Enlisting the support of scientists and engineers to translate science education standards into effective science programs. *J. Coll. Sci Teach* 27, 324-328.

National Research Council (1996). *National science education standards*. Washington, DC: National Academy Press.

Peak, L. (1996). *Pursuing excellence: A study of U. S. eighth-grade mathematics and science teaching, learning, curriculum, and achievement in international context*. Washington, DC: United States Department of Education, OERI.

Peak, L. (1997). *Pursuing excellence: A study of U. S. fourth-grade mathematics and science achievement in international context*. Washington, DC: United States Department of Education, OERI.

Rodger W. Bybee is Executive Director of the Center for Science, Mathematics and Engineering Education of the National Research Council in Washington, DC. (rbybee@nas.edu). Cherilynn A. Morrow is Manager for Education and Out Reach at the Space Sciences Institute in Boulder, CO. (camorrow@colorado.edu)

## NSTA Position Statements on National Standards and on Informal Science Education

The Board of Directors of the National Science Teachers Association has adopted a position statement on the National Science Education Standards that asserts:

1. Teachers, regardless of grade level, should promote inquiry-based instruction and provide classroom environments and experiences that facilitate students' learning of science;
2. Professional development activities should involve teachers in the learning of science and pedagogy through inquiry, and integrate knowledge of science, learning, and pedagogy;
3. Teachers should continually assess their own teaching and students learning;
4. Assessment practices should be varied and focus on both achievement and opportunity to learn, be consistent with the decisions they are designed to inform, and result in sound and fair decisions and inferences;
5. Subject matter stress should be on in-depth understandings of unifying concepts, principles, and themes with less emphasis placed upon lower-level skills, such as the memorization of numerous facts;
6. Inquiry should be viewed as an instructional outcome (knowing and doing) for students to achieve in addition to its use as a pedagogical approach;
7. Science programs should provide equitable opportunities for all students and should be developmentally appropriate, interesting and relevant to students, inquiry-oriented, and coordinated with other subject matters and curricula;
8. Science programs should be viewed as an integral part of a larger educational system that should have policies that are consistent with, and support, all Standards areas and are coordinated across all relevant agencies, institutions, and organizations.

The NSTA Board of Directors has also approved a position statement on informal science education that declares:

1. Informal science education complements, supplements, deepens, and enhances classroom science studies. It increases the amount of time participants can be engaged in a project or topic. It can be

- the proving ground for curriculum materials;
2. The impact of informal experiences extends to the affective, cognitive, and social realms by presenting the opportunity for mentors, professionals, and citizens to share time, friendship, effort, creativity, and expertise with youngsters and adult learners;
3. Informal science education allows for different learning styles and multiple intelligences and offers supplementary alternatives to science study for nontraditional and second language learners. It offers unique opportunities through field trips, field studies, overnight experiences, and special programs;
4. Informal science learning experiences offer teachers a powerful means to enhance both professional and personal development in science content knowledge and accessibility to unique resources;
5. Informal science education institutions, through their exhibits and programs, provide an effective means for parents and other care providers to share moments of intellectual curiosity and time with their children;
6. Informal science institutions give teachers and students direct access to scientists and other career role modes in the sciences, as well as to opportunities for authentic science study;
7. Informal science educators bring an emphasis on creativity and enrichment strategies to their teaching through the need to attract their noncompulsory audiences;
8. NSTA advocates that local corporations, foundations, and institutions fund and support informal science education in their communities;
9. Informal science education is often the only means for continuing science learning in the general public beyond the school years.

Readers are reminded that the Fall 1996 issue of the FEd newsletter featured informal education through science centers. Authors of several articles urged professional physicists to volunteer and become involved with science centers as an effective means to communicate with the public.



## Browsing Through the Journals

Thomas D. Rossing

• The August 14 issue of *Science* has an interesting guest editorial on "Scientific Literacy" by Jane Maienschein and a group of undergraduate students at Arizona State University. The editorial points out the importance of distinguishing between *science literacy*, which focuses on scientific and technical knowledge and *scientific literacy*, which emphasizes scientific ways of knowing and the process of thinking critically and creatively about the natural world. The two approaches are often in tension and have different implications for education, testing, and public funding of science. Promoting scientific literacy requires a new way of teaching for which few teachers are prepared. We need both science literacy and scientific literacy for effective participation in the real world, the authors emphasize.

• On a similar note, two recent guest editorials in *American Journal of Physics* discuss "scientific literacy" and "scientific awareness." In the July issue, Keith Devlin's guest comment "Rather than scientific literacy, colleges should teach scientific awareness" asks whether scientific literacy is an appropriate goal. It is neither possible nor necessary for the general population to have detailed scientific knowledge across a range of disciplines, says Devlin. Science has become too broad, too complex, too specialized for even a scientist to keep up-to-date, and we need to rely on experts. But how do we evaluate the experts? All adults should be scientifically aware, says Devlin, so that they can base their opinions on fact and observable evidence rather than on prejudice or assumptions; be willing to change their opinions based on new evidence; understand cause-and-effect relationships; and appreciate how science is done.

"These are laudable goals, but surely they are even more difficult to embed in our educational system than the communication of basic scientific facts and theories about the world," argues Chet Raymo in a guest comment in the September issue of the same journal entitled "Scientific literacy or scientific awareness?" "It would be fantastic if our schools could turn out citizens who understand and appreciate the scientific process, but the evidence suggests that we are sinking deeper and deeper into a quagmire of superstition, pseudoscience, and New Age quackery." While we move toward Devlin's goal of scientific awareness, let's not give up on scientific literacy. Raymo's minimum scientific literacy for every grade-school graduate would include six bits of knowledge:

1. The world is big;
2. The world is old;
3. The world is made of atoms;
4. The world evolves;
5. Everything is connected;
6. The world is powerful.

These six facts, the product of thousands of years of human curiosity, creativity, and discovery, should be the proud inheritance of every human child.

• "Although national standards, new curricula, professional development programs, new assessment approaches, and deeper insights into how students learn are important

in science education reform, the ultimate pathway to learning boils down to the interaction between teacher and student," writes Marvin Druger in a guest editorial "Inner Guidelines for Undergraduate Teaching" in the September/October issue of *Journal of College Science Teaching*. If we have knowledgeable, well-prepared, creative, reflective, caring, and dedicated teachers in the classroom, students will learn, Druger feels. They will not only learn concepts and information, but they will develop skills in how to learn, a positive attitude toward learning, self-confidence, and a desire to learn as much as possible.

Teaching experience enables us to build a repertoire of inner guidelines and values that serve as directives for our teaching. As unique individuals, each of us has different teaching styles, strengths, and weaknesses, and the same guidelines may not work for all. Research results about teaching and learning are useful, but it takes many years of teaching experience to discover what works, and what does not work. Even after many years of teaching, we are not certain about what constitutes effective teaching and learning.

• A national panel of educators, parents, architects, school board officers, community planners, technology experts, and others has drafted a set of basic principles to serve as guides for communities in designing new learning environments, according to the lead article in the October issue of the U.S. Department of Education's *Community Update*. According to these principles, school designs should:

1. Enhance teaching and learning and accommodate the needs of all learners;
2. Serve as centers of the community;
3. Result from a planning/design process involving all stakeholders;
4. Provide for health, safety, and security;
5. Make effective use of all available resources;
6. Allow for flexibility and adaptability to changing needs.

A discussion of how schools can be built or renovated to meet the educational needs of the 21st century, hosted by Vice President Al Gore and U. S. Secretary of Education Richard Riley, was held in Washington, October 4-5. Information may still be available from the Departments information resource center at 1-800 USA LEARN.

• "Educating Ethical Engineers" in the June issue of *IEEE Spectrum* reports on the discussion of a panel of experts at a meeting of the Association for Practical and Professional Ethics in Dallas on March 1. The discussion was moderated and edited by William Sweet, senior editor. Most panelists noted that in addition to courses in engineering ethics, ethics ought to be included as a component in other engineering courses. In a survey of a focus group from industry, ethics followed mathematics, engineering competence, and communications in order of importance in engineering education, well ahead of computer skills.

• Although references to the "two cultures" generally refers to C. P. Snow's observation of the wide gap between the world views of the scientist and the non-scientist, Jonathan Reichert calls attention to two cultures in the physics com-

munity in a guest editorial "Jack Spratt" in the August issue of *American Journal of Physics*. One group is made up of physics researchers and the other of physics teachers, and communication between the groups appears to be decreasing. "We seem not to pay much attention to each other, each going our separate ways," Reichert points out. "It may not be too much exaggeration to say that we are turning out high school and community college teachers who know how to teach but don't know physics and young faculty who know physics but haven't a clue how to communicate it." This stands in contrast to pre-eminent physicists in the 1950s, such as Zacharias, Purcell, Feynman, and Morrison, who had a deep commitment to both research and communication of physics in all its dimensions.

- "U.K. Science Funding Increase" is the title of an editorial by Prime Minister Tony Blair in the August 21 issue of *Science*. "In investing in our science base, we are building on strength." Mr. Blair points to \$1.5 billion for building and refurbishing university laboratories and equipment as evidence of the investment the Labour government is making in science education. "The Labour government recognizes that the science base is the absolute bedrock of our economic performance, generating the skills, knowledge, and technology that will maintain the United Kingdom's competitive edge in the global markets of the new millennium."

- Another editorial by a high-ranking government official is entitled "French Strategy for Science Education" by Claude Allègre, French Minister for National Education, Research and technology, in the July 24 issue of *Science*. In primary education, the focus will be on key abilities (such as speaking, reading, writing, and counting), teach at least one foreign language, emphasize a hand-on approach to the experimental sciences, and new information technologies. The challenge for secondary schools is to update the curriculum without extending the school week, since programs and contents are far too heavy and not always up to date, Allègre feels. "Shouldn't we stress experiment and observation in physics rather than mathematical concepts?"

Two concepts are being introduced into higher education: internationalization and continuing education. Harmonizing the architecture of diplomas to the European scale will require an undergraduate degree, a shorter master's and a longer Ph.D. The Grandes Ecoles will award the "engineering diploma" at the master's level. For the first time this year, 13 universities will remain open year-round to experiment with continuing education leading to diplomas.

- Dutch universities and research laboratories are set for major cuts, according to a note in the July 30 issue of *Nature*. Cuts are estimated to be around 4 per cent annually until 2002. The cuts will hit universities and research organizations hard. Their budgets are already stretched because of a recent decline in total research spending from 2.3 percent of gross domestic product in 1987 to 1.94 per cent in 1997. The budgetary decisions indicate a significant shift in the government's efforts away from universities and research agencies towards specific state-led projects geared to socioeconomic goals.

- An interesting analysis of "Historical Trends in Physics Bachelor Degree Output" by Robert Ehrlich appears in the September issue of *The Physics Teacher*. The percentage of

bachelor degrees awarded to physics majors in the United States has declined by 75% since 1960. In 1996 the number of physics bachelor recipients hit a 38-year low. Five possible contributing factors are considered: 1. The changing profile of college entrants; 2. The lure of engineering; 3. Physics department resources; 4. Grade inflation; 5. Poor teaching. Large increases in the number of students majoring in engineering and computer science in the 1980s undoubtedly affected the number of physics majors, but both of these fields peaked around 1985 and have been declining ever since. Deservedly or not, physicists have a reputation in industry of being "academic" and not particularly good at or interested in solving real-world problems.

Although some observers have noted that physicists are more engaged in curricular reform than other scientists, many students give poor marks to the teaching in their physics courses. If reliance on old-fashioned pedagogy were a significant cause for low numbers of physics majors, it is difficult to understand why subjects such as biology and psychology, which also rely on lectures and in-class exams, are attracting so many students, Ehrlich comments. Studies show that it is not only students with low grades that drop out of physics. Given that many first tier students now elect engineering rather than physics, we may need to "stalk the second tier" (as Tobias urged in 1990) just to prevent the number of physics majors from shrinking further.

- A statement opposing block granting of the Eisenhower program was endorsed by 37 societies, including the American Institute of Physics and six of its Member Societies: the Acoustical Society of America, the American Association of Physicists in Medicine, the American Association of Physics Teachers, the American Astronomical Society, The American Physical Society, and the American Vacuum Society, according to an FYI bulletin from the AIP Public Information Division, dated September 15. "The science, mathematics, and engineering community remains steadfastly opposed to proposals to transfer the U. S. Department of Education's Eisenhower programs into an education block grant to the states. If Eisenhower funding is shifted into a broader block grant, the resources available to states and localities specifically for mathematics and science education will be dramatically reduced. Such a change grossly undermines our nation's efforts to improve student achievement in these subjects." Other signatories to the statement include the National Science Teachers Association and the National Council of Teachers of Mathematics.

- Although there is a slowly growing movement across the nation to insist on at least 3 years of science and 3 years of mathematics in high school, only half of high school graduates take as much as 2 years of science and less than a quarter of them take 3 years, according to "Coherence in Science Education" by Marjorie Bardeen and Leon Lederman in the July 10 issue of *Science*. The authors argue that there will never be a better time than now to construct a 3-year, coherent, integrated science sequence, appropriately blended with 3 years of mathematics.

Today, students take biology first, then chemistry, and some 25% of the survivors go on to physics. The subjects are treated as completely independent and unrelated, to be learned (and forgotten) in the sequence taken. On the

other hand, searching high school biology texts reveals numerous items from chemistry (such as acids, activation energy, pH, bases, catalysis, chemical bond, conservation of energy, half-life, photosynthesis, and absorption spectra) that are not otherwise explained and hence could be judged to be prerequisites. Similarly searching high school chemistry books reveals numerous physics prerequisites. The authors argue for a coherent 3-year sequence of science courses that would stand alongside English, mathematics, and the social sciences. There are a variety of proposals in the educational literature that would satisfy the demand for coherence and integration, including the authors' proposal for a sequence in which the first course emphasizes physics, the second one chemistry, and the third one biology. The 3-year sequence should also examine the process of science and the role of technology.

- Another article on education reform "U.S. Tries Variations on High School Curriculum" in the same July 10 issue of *Science* calls attention to other integrated science sequences, such as Scope, Sequence, and Coordination (SS&C). SS&C, spearheaded by former NSTA executive director Bill Aldridge, set out to teach each of the science disciplines every year. While good in theory, SS&C ran into serious problems in implementation, including problems developing teaching materials on time and in training teachers. Other schools have adopted "inverted curricula," with physics being taught before chemistry and biology, on their own initia-

tive.

- "Selling physics to unwilling buyers: physics fact and fiction" is the title of an interesting note by Lawrence Krauss in the July issue of *Physics World*. "You meet someone at a party, and they ask you what you do. You tell them you are a physicist. Quickly, they change the topic. But if you ask them if they are interested in black holes, warp drives or time travel, then they are fascinated." Most people think they have little interest in physics, and yet at the same time they are remarkably interested in many of the things that physics deals with, Krauss points out. "The biggest mistake any teacher can make is to assume that the students are interested in what you have to say."

Krauss has written and lectured widely on the physics of *Star Trek*. He reminds his readers and listeners that the show is science fiction; it makes no pretence to describe reality. As Gene Roddenberry, the show's creator said, the Starship Enterprise is primarily a vehicle for drama. The science is thrown in and arbitrarily bent to fit the needs of the plot not *vice versa*. Nevertheless, *Star Trek* has captured the public's imagination. When the Enterprise was exhibited at the Air and Space Museum in Washington, for example, it was the most popular exhibit in the history of the museum far more popular than any real spacecraft that had actually travelled in outer space. What better way could there be, it seemed to the author, to try and reach people than to use an icon of popular culture? Although a great deal of *Star Trek* involves scientific nonsense, the series touches on a range of diverse physical phenomena in one way or another.

## A New Model for Bringing Contemporary Physics Topics into the High School Classroom

Andrew P. Post Zwicker and Nicholas R. Guilbert

**I. Introduction**— Plasma physicists, like Rodney Dangerfield, just don't get much respect. Nearly every year, it seems, someone in the elevator during an APS meeting reads our name badges and asks us if we are medical doctors (plasma  $\rightarrow$  blood  $\rightarrow$  doctor). And fusion, in the mind of the public, is either a form of jazz or something that is vaguely remembered as "cold". In a typical introductory course (which is all the physics most people ever take, if any) the situation is not much better. Fusion is mentioned briefly, if at all, and plasmas are usually skipped altogether. In general, modern or "contemporary" physics is merely sprinkled throughout the standard textbook or else relegated to the last few chapters.

In the scientific press that our students read, however, the situation is very different. Fusion experiments (of either the magnetic-confinement or the inertial-confinement variety) are covered regularly, and plasmas are reported in articles ranging from lightning to the fabrication of semiconductors. Topics like these are what fire our students' interest and imagination, yet they find virtually no place in our introductory courses (largely concerned, as they are, with classical topics). This article describes a first attempt at enhancing students' (and teachers') understanding of a contemporary physics topic by developing both hands-on classroom materials and new pedagogies based on current research in plasma physics and fusion.

**II. Goals**— Our goal was to create a learning environment for secondary-school physics teachers in which they would learn about plasma physics by performing actual plasma physics investigations and then subsequently bring some of those ideas back into their classrooms. We deliberately avoided the model of a "research experience" in which a teacher joins an ongoing experiment for a period of time and is given a "project" to complete. We also did not want the teachers take part merely in "canned" activities. The experiments to be performed were truly open-ended with various levels of sophistication available to each teacher depending upon his or her interests and background. The topics investigated were designed to give the participants both some basic knowledge in plasma physics and some guidance in bringing plasma-related curricula back to their classrooms. This model of teacher- and curriculum-development is unique in several ways and the initial feedback from it has been quite encouraging. The ideas and methods used in it, however, are not specific to plasma physics and can, in principle, be applied to almost any other topic of interest. Similarly, although this particular example used the resources of a government-supported laboratory, the methodology can be applied to almost any laboratory in a university, college, or industry setting.

The most crucial component by far of the design process itself was to bring in from the beginning both a



**Figure 1:** Andrew Post Zwicker (left) discussing equipment used to study the conditions under which a gas can become a plasma with two of the Institute's participants.

researcher (APPZ) in plasma physics and a current high school physics teacher (NRG). We cannot overemphasize the importance of this combination. We brought a working knowledge of plasma physics, laboratory experience, and classroom experience together to create a rigorous yet realistic agenda for the participants. During the course of the Institute, we co-taught all sections. This gave the teachers a colleague they could turn to for advice or questions rather than have an "expert" as their only resource. The increase in trust, rapport, and learning by having the two of us always present was obvious and immediate.

**III. The Institute**—The Plasma Science and Fusion Energy Summer Institute was held for the first time in 1998 as a two-week residential program at the Princeton Plasma Physics Laboratory (PPPL), a national research facility funded by the Department of Energy and administered by Princeton University. The Institute's participants were high school physics teachers selected from a nationwide pool. Applicants were chosen on the basis of three main criteria: physics background, laboratory experience, and a demonstrated willingness to involve students in innovative and open-ended curricula.

A typical day consisted of a morning lecture (on topics such as space plasmas, fusion reactor design or plasma processing of materials) with the remainder of the day devoted to lab work or curriculum development. The laboratory experiments were modifications of PPPL's 'Grad Lab' (Princeton University's Astrophysical Sciences 562), an experimental introduction to plasma physics for beginning graduate students. Experiments investigated plasma formation, plasma spectroscopy, and characterization of plasmas via microwave interferometry, among other issues (see Figure 1). Although the theory behind the experiments was simplified mathematically, the basic content of each laboratory was kept intact. We made a point of demonstrating the applicability of each lab to the teacher's

classes. For example, the spectroscopy lab was tied in to light, optics, electromagnetic waves, collisions (sputtering in the plasma source), magnetism (magnets in the source), and pressure (since the source was under vacuum). We also demonstrated one possible method of simplifying this lab and bringing it back to the classroom (via a fluorescent light bulb as the plasma source and a hand-held spectroscope as the measuring instrument).

Since the typical survey course is already too crowded with topics and is widely criticized for being "a mile wide and an inch deep," the goal for the teachers was to be able to weave plasma physics concepts into existing curricula. Teachers were not asked to create a new "unit" on plasma physics but rather to apply ideas from plasmas and fusion within their current academic structures. Plasma physics concepts can be readily incorporated throughout a typical introductory physics course: optics, electricity and magnetism, thermodynamics, and atomic and nuclear physics are some of the areas in which plasma physics ideas can be used fruitfully. Curricula could include the use of existing material (commercially-made equipment, simulation software, Internet exercises, or common plasma-based light sources), or they could be entirely of a participant's own devising. Attention was paid to the fiscal constraints under which many schools operate, so most of the curricula could be replicated at minimal cost at other schools. Attention was also paid to some of the more political constraints in teaching, such as urban school-district initiatives and current science-education standards and benchmarks. Finally, participants are expected to disseminate their work via (among other avenues) meetings, workshops, or conference presentations. In addition, follow-up grants are available to each participant during this school year for the purpose of buying (or building) plasma-related equipment and for the purpose of paying travel expenses to regional or national meetings.

**IV. Initial Results**—Teachers worked in small groups of their own choosing when designing new curricula based upon common needs (teachers from large urban school districts or from private schools, etc.). Each group was given the task of creating a new curriculum with four separate components: 1) a two- to ten-minute classroom demonstration; 2) a one- to three-period laboratory investigation; 3) a set of five to ten homework (or test) problems or questions; 4) an advanced project for one or more students given sufficient time and resources. Before beginning the assignment, the participants were introduced to available plasma-related equipment. Fluorescent light bulbs with half of the phosphor coating removed (to see the plasma inside the bulb), and a "plasma globe" (a glass sphere with plasma filaments that are attracted to a finger touching the surface of the sphere) were given to each of them to take back to their classrooms. Teachers also received rare earth magnets, spectroscopes, and a plasma/fusion wall chart (developed by the Contemporary Physics Education Project). Finally, more sophisticated equipment is available on loan during the school year including a

microwave interferometer and a visible monochromator.

The curricula developed include a laboratory on plasma spectroscopy with an emphasis on optics and atomic physics, an investigation of the effect of plasma-based light sources on plant growth, and an interactive computer simulation of charged-particle orbits along magnetic field lines in a fusion reactor (Figure 2). Plasma-based test and quiz questions covered topics from astronomy to electricity and magnetism. The various curricula developed during the Institute are available at the Institute's website ([http://ippex.pppl.gov/ippex/summer\\_institute/](http://ippex.pppl.gov/ippex/summer_institute/)).

**V. Assessment**—With a new school year just under way, it is too early to determine how much of the new curricula developed will be actually used in the classroom. Those data will be collected as they become available and used in the planning of future iterations of the Institute. Comments from a post-Institute questionnaire were overwhelmingly positive and included "I don't think one wants to underestimate what a good teacher can take away from this program," "I have at least ten new demos and experiments for class," and "I worked harder at this Institute than at any other summer project I have been involved with." Feedback from the participants identified several factors of the Institute's design which seem to have made this a unique experience and contributed to its success. First, the laboratory experiments were representative of the tools and techniques used by physicists in our research. They challenged the participant's knowledge and experimental techniques in ways that more typical teacher workshops do not. Second, the Institute was designed to connect a participant's own learning with his or her classroom. The teachers were asked to focus on ways to use the ideas from plasmas and fusion in the classroom from the beginning. Finally, the hardware they were given or provided access to, the expectation that they must disseminate their projects, and the "follow-up" grants all demonstrated PPPL's ongoing commitment to extending the experience past the initial two weeks.

**VI. Adaptation of the Concept to Other Contemporary Physics Topics**—Based on these preliminary data, there is no reason why this model of teacher- and curriculum-development cannot be applied to other contemporary physics topics. Key components are: (1) A team consisting of both professional physicist and a current high school teacher; (2) Graduate-level or advanced undergraduate-level labora-

tory work (participants rated this as the most valuable part of the Institute and the most helpful to them as teachers; struggling with and learning new ideas enabled them to experience anew some of the wonder and the frustration that a student feels when taking physics for the first time); (3) Equipment for the classroom (funds to purchase or build equipment during the school year ensures a greater chance of success and a longer-term partnership between the laboratory and the participants); (4) An emphasis on and financial assistance for dissemination; and (5) A multi-year collaboration. Single-shot workshops are, by definition, of a limited value as compared to a long-term collaboration. Next summer all of the participants will be invited back to continue their research and curriculum development work, while at the same time a new group of participants will be brought to the Institute to begin their investigations in plasmas and fusion. The "veterans" will have the opportunity to work with the newcomers and we will begin to move from scientist-teacher learning to teacher-teacher learning.

*Andrew P. Post Zwicker is a member of the Executive Committee of this Forum and a Senior Program Leader in the Science Education Program at the Princeton Plasma Physics Laboratory. Nicholas R. Guilbert is the Secretary of the Contemporary Physics Education Project (CPEP) and a physics teacher at The Peddie School in Hightstown, N.J.*

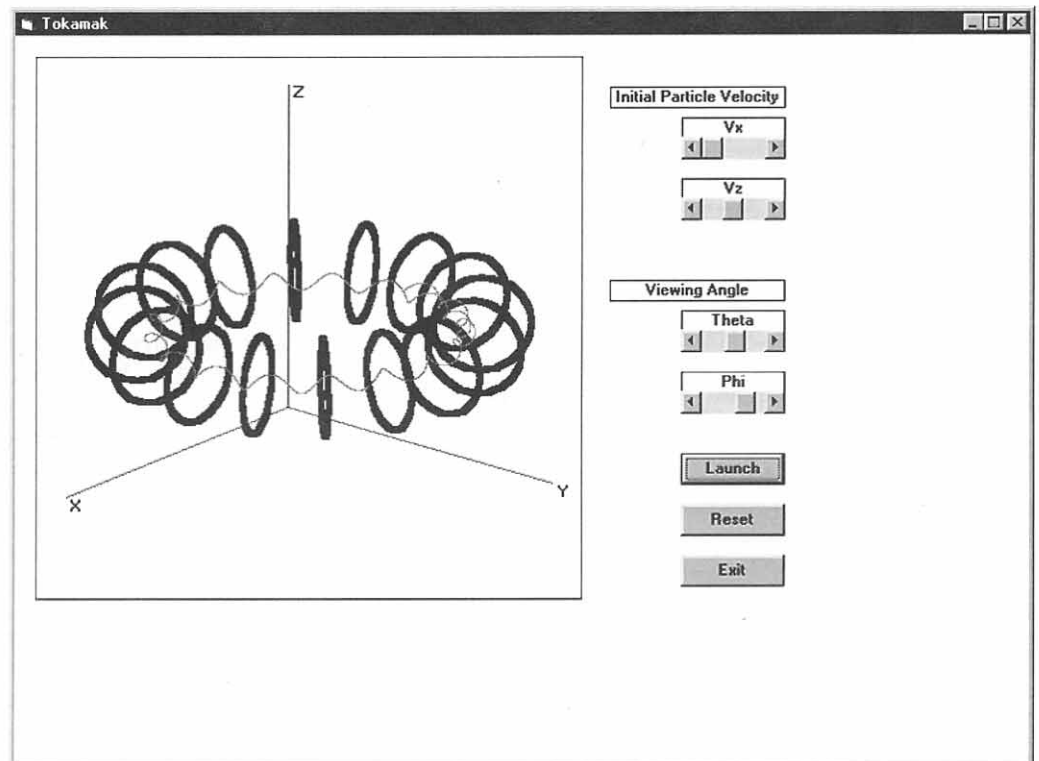

*A screen capture from software developed by Father Michael Liebl of the Mount Michael Benedictine High School in Elkhorn, NE. The software calculates and displays the path of a charged particle in a uniform circular magnetic field (similar to the primary field of a tokamak fusion reactor). The user can control the particle's initial velocity and the viewing angle.*

## From Physics to Business: The Vernier Software Story

Dave Vernier

Vernier Software is a small company that develops and sells software, lab interfaces, sensors, and laboratory manuals to science teachers. The company has grown steadily since its founding in 1981, and is now a major supplier of computerized data acquisition equipment and related material to science teachers. I was asked to write this article on the assumption that some of you would find it interesting how one high school physics teacher started a successful business. I was a pretty good physics student at Ohio State, but I knew that physics graduate study was probably not in the cards for me. As graduation approached I started thinking about teaching physics. My first years teaching were in an inner-city high school where I taught mostly physical science, since there were not many classes in physics. This was a tough school, and I decided right away that I needed to keep the kids busy. I would have the students do a lab almost every day, and I had attention-getting demonstrations much of the rest of the time. This was good training for a new physics teacher. I am still convinced that labs and demonstrations with as much student involvement as possible are the best way to teach physics.

After four years, my wife and I moved to Oregon where I got a masters degree in science at Oregon State. I obtained a position at a suburban Portland high school where I was able to teach physics almost exclusively. I started using programmable calculators and primitive computers in my physics teaching. Some of these were computers that never made it, like Sorcerers and Altairs. In 1979, I bought my first Apple II. It seemed to me that the use of computers in physics classes was a natural.

In the summer of 1981, I tried to find a job, any kind of job, but the Oregon economy was in rather bad shape and jobs were scarce. Neither were there many NSF-funded summer teacher workshops in those days. So I got serious about improving the computer programs I used in my classes with the idea that we might try to sell them some day. Toward the end of the summer, we placed a small ad in the *AAPT Announcer*, and we gradually started selling physics simulation programs. We filled orders and did programming in the evenings and on weekends. It was several years before either my wife or I could give up our daytime jobs.

One major step in the development of the company was getting involved with PASCO Scientific, a physics equipment supplier, at an AAPT meeting. We had brought along our simulation programs and a new program I had just developed called Precision Timer. This program could time a pendulum or a cart or an air-track glider using an infrared beam and a photogate connected to the Apple II game port. I was demonstrating it with simple homemade photogates using Erector set parts as supports. PASCO had nice photogates but not much in the way of software, so we

were a good match. They agreed to sell our software and would promote their photogates.

When IBM marketed their first PC, we felt pressure to develop the programs over again for this platform. This move eventually led to us hiring our first student programmers, and we developed other ways to make measurements with the computer. We wrote programs to use Apple II or IBM computers as chart recorders, frequency meters or oscilloscopes. We supported voltage, temperature, pH, and sound measurements, and we even developed systems that could do near real-time Fourier analysis.

We were originally a software-only company. Even in the cases where the software required sensors, we provided only the software and documentation and encouraged our customers to build their own sensors. At first we included only a schematic, but later we improved the instructions and included a list of Radio Shack parts. After a call from a Wyoming teacher whose nearest Radio Shack is 200 miles away, we decided to sell parts kits and eventually to assemble the hardware and sell it. Hardware that supports data acquisition is now a major part of the company.

In the late 1980s, Priscilla Laws and Ron Thornton invited us to work with them. They had developed a laboratory interface that could work on either Macintosh or IBM-compatible computers, which they called the Universal Lab Interface (ULI). Because it was the only product of its kind available for the Macintosh, and it was supported by good software and physics curriculum material, the ULI became a big hit and led to another growth step for Vernier Software. By 1990 the company had five employees, a small rented office, and was growing quickly. My wife, Christine, was directing the business operation, and I was in charge of R&D.

The next big development was the collaboration with Texas Instruments on sensors and lab manuals for use with their Calculator-Based Laboratory (CBL), which uses a TI graphing calculator instead of a computer. Because of its low cost and portability, the CBL has been a big hit. Most of our sensors and probes can be used with it. We now have 30 different sensors and a dozen books of student-ready experiments for high school and introductory college biology, chemistry, physics, and physical science. Vernier software has grown to about 40 employees. A background in physics teaching provided a great start, but common sense, a wife with business skills, hard work, and luck were important for success.

*David Vernier is a former high school teacher who, with his wife Christine, started Vernier Software, a company that develops and supplies affordable software for physics teaching. This historical sketch of the company was written at the urging of the Editor, who hopes it will encourage other physicists to become entrepreneurs.*

## Revitalization of an Undergraduate Physics Program

John W. Norbury and G. R. Sudhakaran

This article describes the successful revitalization of the undergraduate physics program at the University of Wisconsin-La Crosse. When we started work in 1992 the physics department had a total of 5 physics majors and was in danger of being phased out. Today the department has about 85 majors and is one of the best departments on campus. We describe what we did to achieve this in the hope that other departments in similar situations might be able to use some of our ideas.

Norbury was hired as new department chair at La Crosse in 1992. The dean (Charles Schelin) did this with the specific aim of improving the physics department. Sudhakaran was subsequently hired a year later. We now describe our action plan.

**Academic Programs**—The first thing was to change the academic programs being offered and re-package them in attractive ways directing students, parents and teachers to expand

their typical view of what a physics degree could do for the student. We still continued the core subjects of modern physics, mechanics, electrodynamics, quantum mechanics, thermodynamics and optics and continued two popular astronomy courses and the introductory year long sequences of algebra and calculus based physics courses. However several new courses were added to make the elective list more interesting and useful for the students. Some electives added were quantum optics, electronics, seminar (for credit), research (for credit), computational physics and advanced computational physics, general relativity and cosmology, astrophysics, advanced quantum mechanics and particle physics.

**Emphases and Concentrations**—One of the important additions in attracting new majors was the introduction of a set of emphasis programs that could be packaged along with course and career information. These included physics major with business concentration, physics major with astronomy emphasis, physics major with computational physics emphasis and physics major with optics emphasis.

**Honors Program**—A physics honors program was introduced, in which students are required to submit a formal application, maintain a certain GPA, complete a research project with distinguished performance, give a seminar.

**Dual Degree in Physics and Engineering**—One of the most important programs introduced was a dual degree program in physics and engineering. The program introduced was a collaborative program between our own department and two engineering schools (University of Wisconsin - Madison and University of Wisconsin - Milwaukee). The students spend 3 years in the department at the University of Wisconsin - La Crosse studying selected physics courses and then transfer to one of the engineering schools for 2 years to study an area of engineering. At the end of 5 years they receive two degrees, one in physics and one in engineering.

**Laboratory Upgrades**—As part of improving the academic programs, attention was focused on upgrading the laboratory facilities. During the past five years approximately \$200,000 in laboratory modernization funds were spent. One cannot expect students first and facilities later. They only come together. The freshman physics labs were completely overhauled using computer based "workshop physics" style laboratories. In addition the modern physics lab, optics lab and electronics lab were completely re-done with a full complement of modern experiments and equipment.

**Quality Instruction**—The quality of instruction in all courses (but especially the introductory courses) was improved by trying very hard to use the best instructors. This seems mundane, but is extremely important in building up a physics program.

**Undergraduate Research**—One of the major factors that lead to high student satisfaction with our new program was a strong set of research experiences for the undergraduate physics majors. Students were encouraged and trained to present the results of their work at department seminars and at conferences and to write up their work for publication.

**Funding for Students**—Funding was obtained so that students could work on research over the summer. This also gave the department the opportunity to give students and parents the promise of monetary support and see the immediate connection between learning physics and monetary gain. Again any student getting such support was used for real promotional advantages in the department literature and annual reports.

**Scholarships and Internships**—Major efforts were expended to have material available and get students to apply for scholarships and internships. Several students won very prestigious scholarships (e.g Barry Goldwater scholarship, Council on Undergraduate Research Fellowship, American Physical Society Summer Fellowship), and this had a strong effect on the motivations of the other students. Summer interns were also arranged. One of the best programs here is the 'Research Experiences for Undergraduates' of the National Science Foundation. A great deal of busy work is involved in arranging scholarships and internships but the work is certainly worthwhile as it also helps with recruitment by being able to give examples of the successes of previous students.

**Seminar Program**—A broad seminar program was started. Speakers included faculty from physics and other departments, physics majors and outside speakers. The physics majors would often talk about their research projects and this was a great way for other students to see what opportunities were available. Students also talked about their summer internship experiences. Outside speakers gave talks primarily on research topics, but there were also talks on careers and engineering programs.

**Recruitment, Advising, Retention**—Recruitment and advising appears at first to be another area that seems to be very mundane. However our experience is that the role of the undergraduate physics major advisor is absolutely essential for a successful physics program. The advisor should be very knowledgeable about employment, salaries, current job openings, scholarships, internships, summer jobs, tutoring jobs, housing, international opportunities, graduate record exam, graduate schools, etc.

**Advertising and Brochures**—Advertising is another extremely important area that needed attention. One can have the best physics program in the world, but if no one knows about it, then not much is going to happen. The primary way of advertising was to be in touch with physics high school teachers and counselors and to let them know of the new programs that were available with regular mail outs throughout the year.

**Presenting a Plan and Cooperating with the Administration**—Another aspect of building up the physics program was cooperation and interaction with the university administration. This included not only the deans, provost and chancellor, but also people in the international office, the career center, the counseling center, the affirmative action office, the library, the computer center, etc. Department Teamwork and Priority Mission—Finally we should mention the obvious, that all of the above cannot be done by one person as every aspect needs attention. No one idea is a quick fix that will work but a sustained concerted effort is needed over several years. We were very fortunate to have a few faculty members who really cared about the program and were willing to work very hard as a team to make it succeed. Once it succeeded then we moved into maintenance.

**Conclusions**—Many undergraduate physics departments are faced with problems of low numbers of majors. We have described one successful approach to solving this problem that we hope will be useful to others. Both authors would be happy to help out and consult wherever the need arises.

*John Norbury was department chair at the University of Wisconsin-La Crosse from 1992-96. He is now department chair at the University of Wisconsin-Milwaukee. G. R. Sudhakaran has been department chair at the La Crosse from 1996-present.*

This Newsletter, a publication of **The American Physical Society Forum on Education**, presents news of the Forum and articles on issues of physics education at all levels. Opinions expressed are those of the authors and do not necessarily reflect the views of the APS or of the Forum. Due to limitations of space, notices of events will be restricted to those considered by the editors to be national in scope. Contributed articles, commentary, and letters are subject to editing; notice will be given the author if major editing is required. Contributions should be sent to any of the editors. The Forum on Education website is: <http://www.research.att.com/~kbl/APS/>

## Executive Committee of the Forum on Education

**Paul W. Zitzewitz, Chair (4/00)**  
Dept. of Natural Sciences  
University of Michigan-Dearborn  
4901 Dearborn Rd.  
Dearborn, MI 48128  
(313) 593-5158  
pwz@umich.edu

**Andrea P.T. Palounek, Chair-Elect (4/01)**  
LANL, mail stop H846  
Los Alamos, NM 87545  
(505) 665-2574  
aptp@p2hp2.lanl.gov

**Kenneth J. Heller, Vice-Chair (4/02)**  
School of Physics and Astronomy  
University of Minnesota  
Minneapolis, MN 55455  
(612) 624-7314  
heller@mnhep.hep.umn.edu

**Morton R. Kagan, Secretary-Treasurer (4/99)**  
813 Litchfield Tpke  
Bethany, CT 06524  
(203) 393-0752  
mkagan@snet.net

**Rush D. Holt, Past Chair (4/99)**  
273 Pennington-Rocky Hill Road  
Pennington, New Jersey 08534  
(609) 737-2343  
rholt@pluto.njcc.com

**James Wynne, Forum Councillor (4/00)**  
IBM/T.J. Watson Research Center  
Yorktown Heights, NY 10598  
(914) 945-1575  
jjwynne@us.ibm.com

**Andrew Post Zwicker, APS Member-at Large (4/01)**  
Science Education Program  
Princeton Plasma Physics Laboratory  
PO Box 451  
Princeton, NJ 08543  
(609) 243-2150  
azwicker@pppl.gov

**Barbara G. Levi, Gen. Member-at Large (4/00)**  
1616 La Vista del Oceano  
Santa Barbara, CA 93109  
(805) 965-3483  
bgl@worldnet.att.net

**Helen Quinn, Gen. Member-at-Large (4/99)**  
Stanford Linear Accelerator  
Stanford, CA 94309  
(415) 926-2713  
QUINN@slac.stanford.edu

**Kenneth S. Krane, APS/AAPT Member-At-Large (4/98)**  
Department of Physics  
Oregon State University  
Corvallis, OR 97331-6507  
(541) 737-4569  
krane@ucs.orst.edu

**David G. Haase, APS/AAPT Member-At-Large (4/00)**  
Department of Physics  
North Carolina State University  
Box 8202  
Raleigh, NC 27695  
(919) 515-6118  
david\_haase@ncsu.edu

**Jack M. Wilson, APS/AAPT Member-at-Large (4/99)**  
Dean of Undergraduate Education  
Rensselaer Polytech Institute  
CII 4011  
Troy, NY 12180  
(518) 276-4853  
wilsoj@rpi.edu

### NON-VOTING MEMBERS OF THE FED EXECUTIVE COMMITTEE

**Ken Lyons, Homepage Administrator**  
AT&T Labs Research  
180 Park Avenue  
Florham Park, NJ 07932  
(973) 360-8663  
kbl@research.att.com

**Howard Voss, AAPT Representative**  
Arizona State University  
Department of Physics and Astronomy  
Tempe, AZ 85287  
(602) 965-6794  
howard.voss@asu.edu

**Lori Goldner (Chair APS Committee on Education)**  
NIST  
Bldg 220 Rm A320  
Gaithersburg, MD 20899  
(301) 975-3792  
lori.goldner@bruce.nist.gov

**Ramon E. Lopez, APS Representative**  
Director, Education and Outreach Programs  
APS  
One Physics Ellipse  
College Park, MD 20740-3844  
(301) 209-3263  
lopez@aps.org

## Newsletter Editors

**Spring Issue**  
(Deadline for contributions: Feb. 1)  
**Stan Jones**  
Department of Physics and Astronomy  
Box 870324  
The University of Alabama  
Tuscaloosa, AL 35487-0268  
205-348-5050  
fax: 205-348-5051  
email: sjones@gallalee.as.ua.edu

**Summer Issue**  
(Deadline: June 1)  
**Samuel P. Bowen**  
Department of Chemistry and Physics  
Chicago State University  
9501 S. King Drive  
Chicago, IL 60628-1598  
773-995-3804  
fax: 773-995-3809  
s-bowen1@csu.edu

**Fall Issue**  
(Deadline: Oct. 1)  
**Thomas D. Rossing**  
Department of Physics  
Northern Illinois University  
DeKalb, IL 60115-2854  
815-753-6493  
fax: 815-753-8565  
rossing@phys.niu.edu

**The American Physical Society**

One Physics Ellipse  
College Park, MD 20740-3844

Non-Profit Org.  
U.S. Postage  
**PAID**  
College Park, MD  
Permit No. 1233